



4K2K

HDBT^{ASO}

HDCP2.2



PUV-1620S-TX

4K UHD HDMI / VGA to HDBaseT Transmitter Switcher/
Scaler, IR, Audio Embedding, RS-232, LAN, PoH

OPERATION MANUAL

DISCLAIMERS

The information in this manual has been carefully checked and is believed to be accurate. CYP (UK) Ltd assumes no responsibility for any infringements of patents or other rights of third parties which may result from its use.

CYP (UK) Ltd assumes no responsibility for any inaccuracies that may be contained in this document. CYP (UK) Ltd also makes no commitment to update or to keep current the information contained in this document.

CYP (UK) Ltd reserves the right to make improvements to this document and/or product at any time and without notice.

COPYRIGHT NOTICE

No part of this document may be reproduced, transmitted, transcribed, stored in a retrieval system, or any of its part translated into any language or computer file, in any form or by any means—electronic, mechanical, magnetic, optical, chemical, manual, or otherwise—without express written permission and consent from CYP (UK) Ltd.

© Copyright 2011 by CYP (UK) Ltd.

All Rights Reserved.

Version 1.1 August 2011

TRADEMARK ACKNOWLEDGMENTS

All products or service names mentioned in this document may be trademarks of the companies with which they are associated.

SAFETY PRECAUTIONS

Please read all instructions before attempting to unpack, install or operate this equipment and before connecting the power supply.

Please keep the following in mind as you unpack and install this equipment:

- Always follow basic safety precautions to reduce the risk of fire, electrical shock and injury to persons.
- To prevent fire or shock hazard, do not expose the unit to rain, moisture or install this product near water.
- Never spill liquid of any kind on or into this product.
- Never push an object of any kind into this product through any openings or empty slots in the unit, as you may damage parts inside the unit.
- Do not attach the power supply cabling to building surfaces.
- Use only the supplied power supply unit (PSU). Do not use the PSU if it is damaged.
- Do not allow anything to rest on the power cabling or allow any weight to be placed upon it or any person walk on it.
- To protect the unit from overheating, do not block any vents or openings in the unit housing that provide ventilation and allow for sufficient space for air to circulate around the unit.

REVISION HISTORY

VERSION NO.	DATE	SUMMARY OF CHANGE
v1.00	20/06/2018	First release

CONTENTS

1. Introduction	6
2. Applications	6
3. Package Contents	6
4. System Requirements	7
5. Features	7
6. Operation Controls and Functions	8
6.1 Front Panel	8
6.2 Rear Panel	9
6.3 IR Cable Pinouts	10
6.4 OSD Menu	10
7. Connection Diagram	18
8. Specifications	19
8.1 Technical Specifications	19
8.2 Video Specifications	20
8.3 Audio Specifications	21
8.4 Cable Specifications	22
8.5 HDBaseT Features	22
9. Acronyms	23

1. INTRODUCTION

This Transmitter is designed to scale and convert HDMI and PC video, with optional analogue audio embedding, for extension over long distances to standard HDBaseT Receivers. The HDMI input supports resolutions up to 4K@60Hz and the VGA input supports resolutions up to 1080p60/WUXGA (RB). The scaled HDBaseT output supports resolutions from 640×480@60Hz up to 4K@60Hz (4:2:0, 8-bit) and provides the ability to adjust the image with a number of fine tuning options including: contrast, brightness, hue, saturation, sharpness, noise reduction, and RGB levels.

Furthermore, this unit supports passing 7.1 channel LPCM digital audio as well as advanced Bitstream and HD Bitstream audio formats via the HDMI input, or analogue stereo audio may be embedded from the provided stereo mini-jack connection. Shortcut keys are provided to quickly change the output resolution to 1080p60 or XGA when needed for quick connection to a display or for troubleshooting purposes.

Additionally, the unit may be powered locally or via 48V PoH (Power over HDBaseT) from a compatible HDBaseT Receiver, which allows for greater flexibility in installations. The unit can be controlled via front panel buttons with a comprehensive OSD.

2. APPLICATIONS

- /// Presenter device display in classrooms and lecture halls
- /// PC/Laptop presentation switching in boardrooms
- /// Using classic media players with 4K HDMI displays

3. PACKAGE CONTENTS

- /// 1×HDMI/VGA to HDBaseT Scaler (PD)
- /// 1×5V/2.6A DC Power Adapter
- /// 1×3.5mm to IR Extender Cable
- /// 1×3.5mm to IR Blaster Cable
- /// 1×3-pin Terminal Block to 9-pin D-sub Adapter Cable
- /// 1×Shockproof Feet (Set of 4)
- /// 1×Operation Manual

4. SYSTEM REQUIREMENTS

- /// HDMI or VGA source equipment such as media players, video game consoles, PCs or set-top boxes.
- /// A compatible HDBaseT receiver with 48V PoH support is strongly recommended.
- /// The use of “Premium High Speed HDMI” cables is highly recommended.
- /// The use of industry standard Cat.6, Cat.6a or Cat.7 cable is highly recommended.

5. FEATURES

- /// HDMI 2.0 and DVI 1.0 compatible
- /// HDCP 1.x and HDCP 2.2 compliant
- /// 1 HDMI and 1 PC input
- /// 1 Analogue Stereo Audio input
- /// 1 HDBaseT output
- /// HDMI input supports input resolutions up to 4K@60Hz
- /// VGA input supports resolutions up to 1080p60/WUXGA (RB)
- /// Scaled HDBaseT output supports resolutions from 640x480@60Hz up to 4K@60Hz (4:2:0, 8-bit)
- /// HDBaseT feature support: HD Video and Audio, 100BaseT Ethernet, 48V PoH, and Control (bidirectional IR/RS-232 pass-through)
- /// Simultaneous transmission of uncompressed video, audio and data over a single 100m/328ft Cat.5e/6/7 cable at 1080p60 and 70m/230ft at 4K
- /// Supports pass-through of LPCM 7.1, Bitstream and HD Bitstream audio formats
- /// Analogue stereo audio insertion support via stereo mini-jack
- /// Unit may be powered locally or via 48V PoH from a compatible HDBaseT Receiver (PSE)
- /// Controllable via front panel buttons with comprehensive OSD

6. OPERATION CONTROLS AND FUNCTIONS

6.1 Front Panel

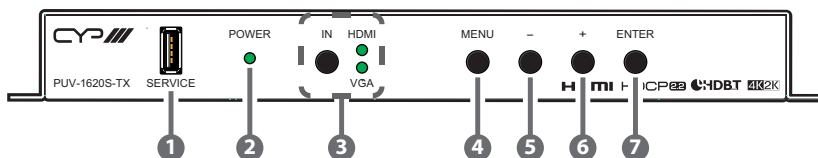

- ① **SERVICE:** This is reserved for firmware update use only.
- ② **POWER LED:** This LED will illuminate to indicate the unit is on and receiving power.
- ③ **IN Button & LEDs:** Press this button to switch between the HDMI and VGA inputs. The LED will illuminate to indicate which source is currently selected.
- ④ **MENU:** Press to enter the OSD menu, or to back out from menu items.
Note: Pressing "MENU" and "+" together will reset the output resolution to XGA (1024×768@60Hz). Pressing "Menu" and "-" together will reset the output resolution to 1080p@60Hz.
- ⑤ **-:** Press to move down or adjust selections within OSD menus.
- ⑥ **+:** Press to move up or adjust selections within OSD menus.
Note: Pressing and holding the "+" and "-" keys at the same time for more than 3 seconds will perform a factory reset of the unit.
- ⑦ **ENTER:** Press to confirm a selection within the OSD or to go deeper into a menu item.

6.2 Rear Panel

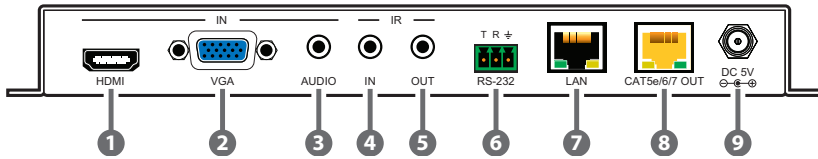

- 1 HDMI IN:** Connect to HDMI source equipment such as a media player, game console or set-top box. DVI sources are supported with the use of an HDMI to DVI adapter.
- 2 VGA IN:** Connect to VGA source equipment such as a PC or laptop.
- 3 AUDIO IN:** Connect to the stereo analogue output of a device such as a CD player or PC.
- 4 IR IN:** Connect to the provided IR Extender to extend the IR control range of devices connected to the other end of the HDBaseT connection. Ensure that the remote being used is within direct line-of-sight of the IR Extender.
- 5 IR OUT:** Connect to the provided IR Blaster to transmit IR signals from the other end of the HDBaseT connection to devices within direct line-of-sight of the IR Blaster.
- 6 RS-232:** Connect to a PC, laptop or other serial control device for the extension of RS-232 signals.
- 7 LAN:** Connect to an Ethernet supporting device or to your local network, as appropriate, to extend the network to both ends of the HDBaseT connection.
- 8 CAT5e/6/7 OUT:** Connect to a compatible HDBaseT Receiver with a single Cat.5e/6/7 cable for transmission of all data signals.
- 9 DC 5V:** Plug the 5V DC power adapter into the unit and connect it to an AC wall outlet for power. (Optional)

Note: This unit can be powered completely via HDBaseT if connected to a compatible 48V PoH PSE (Power Supplying Equipment) Receiver. Use of the 5V DC power adapter is optional in that case.

6.3 IR Cable Pinouts

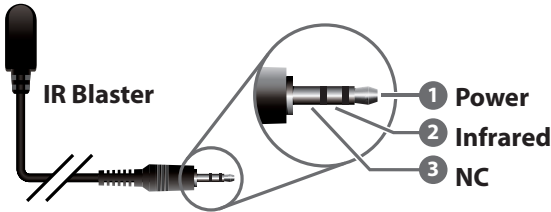
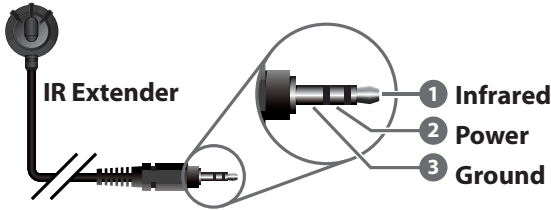

6.4 OSD Menu

All functions of this unit can be controlled by using the OSD (On Screen Display) which is activated by pressing the Menu button on the front of the unit. Use the + (PLUS), – (MINUS), and ENTER buttons to navigate the OSD menu. Press the Menu button to back out from any menu item and then press it again to close the menu.

MAIN MENU
Picture
Input
Output
OSD
Miscellany
Factory
Information

The individual functions of the OSD will be introduced in the following section. Items marked in **BOLD** are the factory default settings.

PICTURE		
LEVEL 2	LEVEL 3	LEVEL 4
Brightness	0~100 (50)	
Contrast	0~100 (50)	
Finetune	Hue	0~100 (50)
	Saturation	0~100 (50)
	Sharpness	0~100 (0)
	Noise Reduction	OFF
		Low
Middle		
High		
Auto		
Colour	Red	0~100 (50)
	Green	0~100 (50)
	Blue	0~100 (50)

- 1) **Brightness:** Provides control over the overall brightness of the scaled output image.
- 2) **Contrast:** Provides control over the overall contrast of the scaled output image.
- 3) **Finetune (Hue):** Provides control over the hue shift of the scaled output image.

Finetune (Saturation): Provides control over the colour saturation level of the scaled output image.

Finetune (Sharpness): Provides control over the amount of sharpness processing to apply to the scaled output image.

Finetune (Noise Reduction): Provides control over the aggressiveness of the digital noise reduction processing when applied to the scaled output image. Selecting “Off” disables all noise reduction processing.

- 4) **Colour (Red/Green/Blue):** Provides control over the red, green, and blue colour level of the scaled output.

INPUT	
LEVEL 2	LEVEL 3
Video Source	HDMI
	PC
Audio Source	EMBEDDED
	Automatic
	Analogue

- 1) **Video Source:** Selects the input source to display.
- 2) **Audio Source:** Provides control over the audio source to use with the HDMI input. Selecting “Embedded” passes the HDMI source’s audio without modification. Selecting “Analogue” embeds the analogue audio source into the HDMI signal for output. Selecting “Automatic” allows the unit to automatically use the analogue audio source if no audio is detected from the HDMI input.

OUTPUT	
LEVEL 2	LEVEL 3
Size	Overscan
	Full
	BEST FIT
	Pan Scan
	Letterbox
	Underscan
	Follow In
4K In -> 4K Out	BYPASS
	Scaler
Resolution	NATIVE
	640×480 60
	800×600 60
	1024×768 60
	1280×768 60
	1360×768 60
	1280×720 60
	1280×800 60
	1280×1024 60
	1440×900 60
	1400×1050 60
	1680×1050 60
	1600×1200 60
	1920×1080 60
	1920×1200 60
720×480p 60	
720×576p 50	

OUTPUT	
LEVEL 2	LEVEL 3
	1280×720p 50
	1280×720p 60
	1920×1080p 24
	1920×1080p 25
	1920×1080p 30
	1920×1080p 50
	1920×1080p 60
	4K2K 24
	4K2K 25
	4K2K 30
	4K2K (4:2:0) 50
	4K2K (4:2:0) 60

- 1) Size:** Selects the aspect ratio to use when outputting the source. “Full” stretches the source to fill the output resolution, regardless of the original aspect ratio, while “Best Fit” will always attempt to retain the original source’s correct aspect ratio by adding black bars if necessary. “Follow In” centers the source on the screen, without any scaling (1:1 pixel reproduction).

Notes: This menu is only available when scaler mode is enabled and the input/output is not 4K with matching refresh rates. When “Follow In” is used with 4K sources the input resolution will automatically be reduced to 1080p prior to output.

- 2) 4K In -> 4K Out:** Selecting “Bypass” forces the unit to pass all 4K sources without modification (scaling or frame rate conversion). Selecting “Scaler” allows the unit to scale 4K sources when they do not match the output resolution exactly.

Note: If a 4K source exactly matches the selected output resolution it will be output in bypass mode, even if “Scaler” mode is selected.

- 3) Resolution:** Selects the output resolution to use. Selecting “Native” will make the unit automatically select an output resolution based on the detected EDID of the connected display.

OSD	
LEVEL 2	LEVEL 3
H-Position	0~100 (50)
V-Position	0~100 (50)
Timer	OFF
	5s
	10s
	15s
	20s
	25s
	30s
	35s
	40s
	45s
Timer	50s
	55s
	60s
Transparent	0~100 (100)
Display	Off
	On
	INFO

- 1) **H-Position:** Set the horizontal position of the OSD menu.
- 2) **V-Position:** Set the vertical position of the OSD menu.
- 3) **Timer:** Set the length of time to wait before automatically turning off the OSD menu if there is no user interaction. The timer may also be disabled.
- 4) **Transparent:** Set the transparency level of the OSD menu. A setting of 100 is completely opaque.
- 5) **Display:** Control the visibility of the on screen information display.

Selecting “Info” will show the information display for a few seconds before automatically turning it off after a source or resolution change.

MISCELLANY		
LEVEL 2	LEVEL 3	LEVEL 4
HDCP On Input	ON	
	Off	
HDCP On Output	FOLLOW OUTPUT	
	Follow Input	
Auto Sync Off	DISABLE	
	Fast	
	Slow	
Auto Input	On	
	OFF	
EDID Manage	HDMI EDID	DEF. 1080P
		Def. 4K2K (3G)
		Def. 4K2K (4:2:0)
		Def. 4K2K (6G)
		Output

- 1) **HDCP On Input:** Enables or disables HDCP support on the HDMI input.
- 2) **HDCP On Output:** Sets the HDCP version selection logic to use with the output signal. Selecting “Follow Input” will cause the unit to output using the HDCP version required by the currently connected source. Selecting “Follow Output” will always output using the maximum supported HDCP version reported by the connected receiver.
- 3) **Auto Sync Off:** Sets the relative amount of time to continue outputting black with sync if there is no live source and no operations have been executed on the unit. Setting this to “Disable” forces the unit to always output sync.
- 4) **Auto Input:** Enables or disables automatically switching on source loss or when a new live input has been detected.

- 5) **EDID Manage (HDMI EDID):** Select the EDID to use with the HDMI input. Selecting “Output” will use the EDID copied from the currently connected receiver.

FACTORY	
LEVEL 2	LEVEL 3
Reset	NO
	Yes

- 1) **Reset:** Selecting YES will reset all of the unit’s settings back to their factory defaults.

INFORMATION	
LEVEL 2	LEVEL 3
Source	[Current Status Details]
Input	
Output	
Valens Version	
Version	

- 1) **Information:** This screen displays information about the unit’s current state, input and output status, as well as the current Valens and unit firmware versions.

7. CONNECTION DIAGRAM

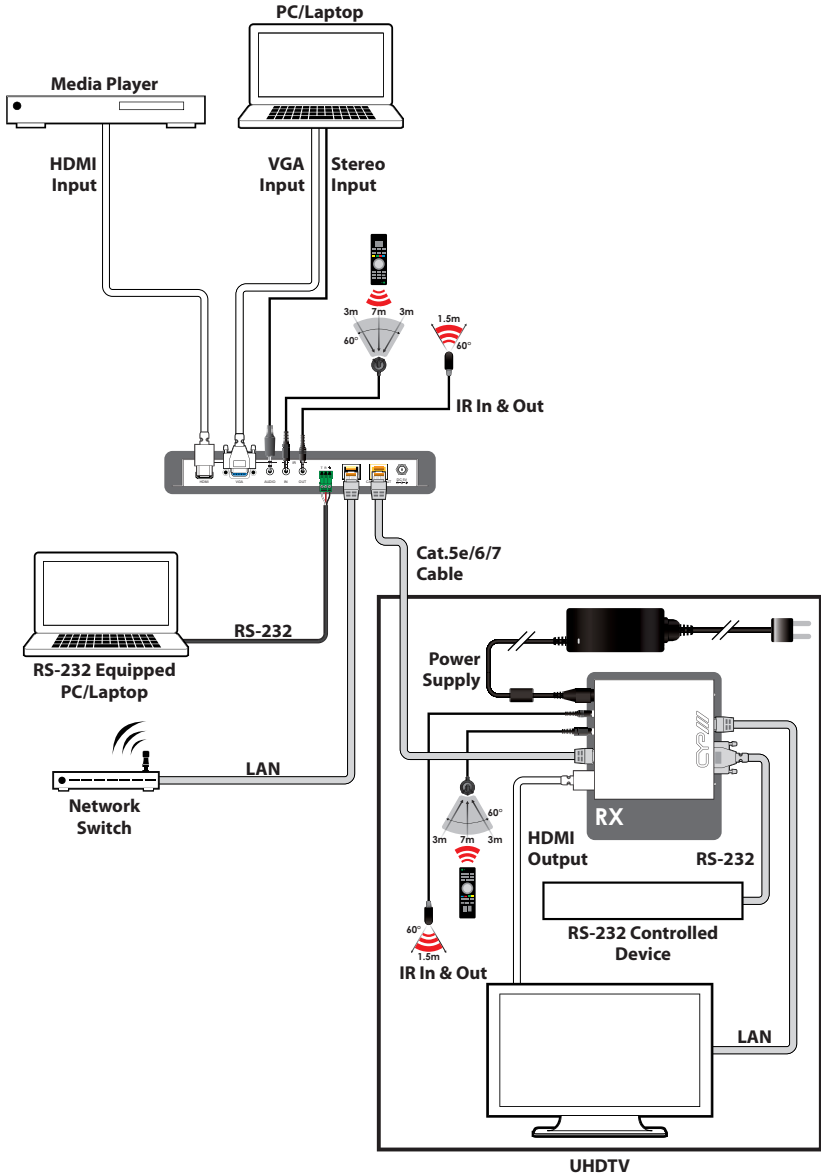

8. SPECIFICATIONS

8.1 Technical Specifications

HDMI Bandwidth	600MHz/18Gbps
HDBaseT Bandwidth	340MHz/10.2Gbps
Input Ports	1×HDMI 1×VGA 1×Stereo (3.5mm)
Output Port	1×HDBaseT (RJ45)
Pass-through Ports	1×IR Extender (3.5mm) 1×IR Blaster (3.5mm) 1×RS-232 (3-pin Terminal Block) 1×LAN (RJ45)
IR Frequency	30–50kHz (30–60kHz under ideal conditions)
Baud Rate	Up to 115200bps
Power Supply	5V/2.6A DC (US/EU standards, CE/FCC/UL certified)
ESD Protection	Human Body Model: ±8kV (Air Discharge) ±4kV (Contact Discharge)
Dimensions	231.5mm×25mm×158mm (W×H×D) [Case Only] 231.5mm×30mm×166.7mm (W×H×D) [All Inclusive]
Weight	898g
Chassis Material	Metal
Silkscreen Colour	Black
Operating Temperature	0 °C–40 °C/32 °F–104 °F
Storage Temperature	-20 °C–60 °C/-4 °F–140 °F
Relative Humidity	20–90% RH (Non-condensing)
Power Consumption	8.3W/19.6W (PoH)

8.2 Video Specifications

Supported PC Resolutions (Hz)		HDMI Input	VGA Input	HDBaseT Output
640×480	60, 72, 75, 85	✓	✓	60
800×600	56, 60, 72, 75, 85	✓	✓	60
1024×768	60, 70, 75, 85	✓	✓	60
1280×768	60, 75, 85	✓	✓	60
1360×768	60	✓	✓	✓
1280×720	60	✓	✓	✓
1280×800	60	✓	✓	✓
1280×1024	60	✓	✓	✓
1440×900	60	✓	✓	✓
1400×1050	60	✓	✓	✓
1680×1050	60	✓	✓	✓
1600×1200	60	✓	✓	✓
1920×1080	60	✓	✓	✓
1920×1200	60 (RB)	✓	✓	✓

Supported TV Resolutions (Hz)		HDMI Input	VGA Input	HDBaseT Output
720×480i	60	✓	✗	✗
720×576i	50	✓	✗	✗
720×480p	60	✓	✗	✓
720×576p	50	✓	✗	✓
1280×720p	50, 60	✓	✗	✓
1920×1080i	24, 25, 30, 50, 60	✓	✗	✗
1920×1080p	24, 25, 30, 50, 60	✓	✗	✓
3840×2160p	24, 25, 30	✓	✗	✓

Supported TV Resolutions (Hz)		HDMI Input	VGA Input	HDBaseT Output
3840×2160p (YUV 4:2:0)	50, 60	✓	×	✓
3840×2160p	50, 60	✓	×	×
4096×2160p	24, 25, 30	✓	×	×
4096×2160p (YUV 4:2:0)	50, 60	✓	×	×
4096×2160p	50, 60	✓	×	×

8.3 Audio Specifications

Analogue Input	
Max Audio Level	2Vrms
Impedance	499kΩ
Type	Unbalanced

8.4 Cable Specifications

HDMI Cable Length	1080p		4K
	8-bit	12-bit	8-bit
Input	10m	10m	5m

Cat. Cable Length	1080p	4K
Cat.5e	100m	70m
Cat.6	100m	70m
Cat.7	100m	100m

Full HD Video (1080p)

- Up to 1080p@60Hz, 12-bit colour
- Data rates lower than 5.3Gbps or below 225MHz TMDS clock

Ultra HD Video (4K)

- 4K@24, 25, 30Hz & 4K@50, 60Hz (YUV 4:2:0), 8-bit colour
- Data rates higher than 5.3Gbps or above 225MHz TMDS clock

8.5 HDBaseT Features

HDBaseT Feature	Supported
Video & Audio	✓
IR Pass-through	✓
RS-232 Pass-through	✓
Accept power from Receiver	✓
Send power to Receiver	×
LAN Pass-through	✓

9. ACRONYMS

ACRONYM	COMPLETE TERM
Cat.5e	Category 5 (enhanced) cable
Cat.6	Category 6 cable
Cat.7	Category 7 cable
CEC	Consumer Electronics Control
DVI	Digital Visual Interface
EDID	Extended Display Identification Data
HD	High-Definition
HDCP	High-bandwidth Digital Content Protection
HDMI	High-Definition Multimedia Interface
HDR	High Dynamic Range
HDTV	High-Definition Television
IR	Infrared
LAN	Local Area Network
LPCM	Linear Pulse-Code Modulation
OSD	On-Screen Display
PC	Personal Computer
PD	Powered Device
PoH	Power over HDBaseT
PSE	Power Sourcing Equipment
UHD	Ultra-High-Definition
UHDTV	Ultra-High-Definition Television
USB	Universal Serial Bus
VGA	Video Graphics Array
WUXGA (RB)	Widescreen Ultra Extended Graphics Array (Reduced Blanking)